

Vegetables

Darrin Parmenter
CSU Extension - La Plata County

1

Gardening Goals

Maximize time	Space utilization
Nutritious food	Fresh air
Conversation friendly	Environmentally friendly
Continue traditions	Food security

2

How Much Should I Grow?

- How many mouths am I feeding?
- What does my calendar look like this summer and fall?
- Do I have help?
- Do I have the ability to store food?
- Am I comfortable with food preservation?
- Do I have the ability to plant an extra row?

3

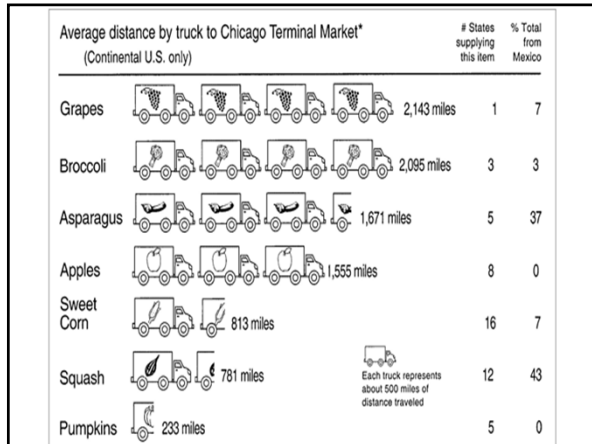

4

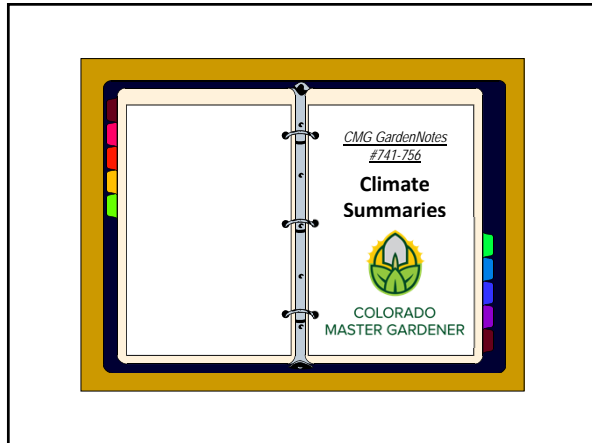

5

YEAR	LAST FROST	FIRST FROST	SEASON LENGTH
2009	1-May	22-Sep	144
2010	30-May	25-Oct	148
2011	31-May	10-Oct	132
2012	30-May	7-Oct	130
2013	1-Jun	28-Sep	119
2014	15-Jun	3-Oct	110
2015	20-May	3-Oct	136
2016	28-May	16-Sep	111
2017	14-Jun	24-Sep	102
2018	17-May	27-Sep	133
2019	23-Jun	22-Sep	91
AVERAGE	31-May	2-Oct	124

6

Cool Season Crops	
Hardy vegetables Broccoli, cabbage, kohlrabi, onions, lettuce, peas, radish, spinach, etc.	Semi-hardy vegetables Beets, carrots, cauliflower, parsnips, potatoes, Swiss chard, etc.
Daytime Temperatures (F°)	
>40°	>40° to >50°
Night Temperatures (F°)	
Survives frosty nip	Less tolerant of frosty nip
Typical Planting Time	
2-4 week before average spring frost date	0-2 weeks before average spring frost date

10

Warm Season Crops	
Tender vegetables Beans, corn, cucumber, summer squash, etc.	Very tender vegetables Cantaloupe, eggplant, peppers, winter squash and pumpkins, tomatoes, watermelon, etc.
Daytime Temperatures (F°)	
>60° minimum	> 60° minimum a week below 55° will stunt plants
Night Temperatures (F°)	
Intolerant of frost	Intolerant of frost
Typical Planting Time	
planted from seed about time of average spring frost	1+ weeks after average spring frost date, summer-like temperatures

11

Soil temperatures is a good method to judge planting times

Measure

- 4-inch deep
- 8 a.m.



461

12

Raising Soil Temperatures

- Soil heat up quickly when dry.
- Wet soil put 90+% of the sun's energy into drying the soil and are slow to warm.



461

13

**Soil Temperature Conditions for Vegetable Seed Germination
(in degrees F)**

Crop	Minimum	Optimum Range	Optimum	Maximum
Asparagus	50	60-85	75	95
Bean	60	60-85	80	95
Beet	40	50-85	85	95
Cabbage	40	45-95	85	100
Carrot	40	45-85	80	95
Cauliflower	40	45-85	80	100
Chard, Swiss	40	50-85	85	95
Corn	50	60-95	95	105
Cucumber	60	60-95	95	105
Eggplant	60	75-90	85	95
Lettuce	35	40-80	75	95
Muskmelon	60	75-95	90	100
Onion	35	50-95	75	95
Parsley	40	50-85	75	90
Parsnip	35	50-70	65	85
Pea	40	40-75	75	85

14

**Days to Appearance of Seedlings at Various Soil Temperatures from
Seed Planted at 1/2" Depth**

Crop	Soil temperature in degrees F									
	32	41	50	59	68	77	86	95	104	
Asparagus	x	x	53	24	15	10	11	19	28	
Bean	x	x	x	16	11	8	6	6	x	
Beet	...	42	17	10	6	5	4	4	...	
Cabbage	15	9	6	4	3	
Carrot	x	51	17	10	7	6	6	8	x	
Cauliflower	19	10	6	5	4	
Corn	x	x	22	12	7	4	4	3	x	
Cucumber	x	x	x	13	6	4	3	3	...	
Eggplant	13	8	5	
Lettuce	49	15	7	4	3	2	2	x	x	
Muskmelon	8	4	3	
Onion	135	31	13	7	5	4	4	12	x	
Parsley	29	17	14	13	12	
Parsnip	171	57	27	19	14	15	32	x	x	
Pea	...	36	13	9	7	6	6	
Pepper	x	x	x	25	12	8	8	9	x	

15

Vegetable Transplantability

Easily Survives Transplanting

Beet	Strawberry
Broccoli	Lettuce
Cabbage	Pepper
Chard	Tomato
Collards	Eggplant

16

Requires Care in Transplanting

Carrot	Watermelon
Celery	Spinach
Kale	Parsley
Kohlrabi	Mustard

17

Difficulty in Transplanting

Bean

Corn

Cucumber

Cantaloupe

Okra

Peas

Squash

Turnips

18

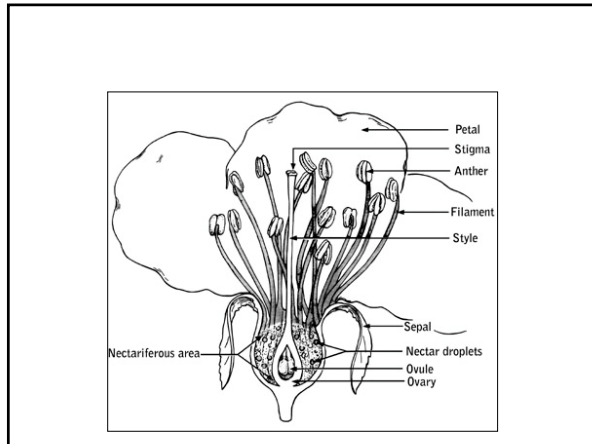

19

Botany 101

Flowering Habits

- **Monoclinous:** both sexes on same flower (bean, tomato, lettuce)
- **Monoecious** – separate staminate (♂) and pistillate (♀) flowers on same plant (corn, cucurbits)
- **Dioecious** – staminate and pistillate flowers on different plants (spinach, asparagus)
- **Gynoecious** – having only pistillate flowers (some cucumber lines)

20

Pollination

Self	Air	Insect
Beans	Carrots	Cucumber
Tomato	Celery	Eggplant
	Corn	Squashes
	Onions	Melons
	Spinach	Peppers
		Watermelon

21

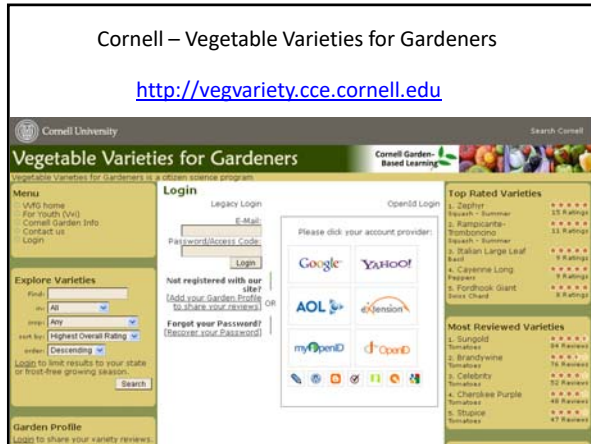

22

Heirloom vs. Hybrid

Heirlooms: the importance of diversity

- Genetic diversity offers possibility of disease resistance
- Flavor variances to please every palate
- Varietal tolerances to environmental challenges

Hybrids: improvements for modern conditions

- Higher disease resistance
- Uniform produce
- Reliable performance
- Higher sugars

23

Climate

What are components of our local climate?

- Frost-Free days
- Temperature & weather extremes
- Unpredictability
- Intense sun
- Cold nights
- Low humidity
- Susceptible to drought
- Microclimate

24

Transplant

<p>Advantages</p> <ul style="list-style-type: none"> • Climate Control • Season Extension • Intensive Seedling Management • Rapid Crop Successions • Fibrous Root Nature • Efficiency with Seed & Resources 	<p>Disadvantages</p> <ul style="list-style-type: none"> • Costs in infrastructure, containers & soil media • Increase labor & skills necessary • Not practical for all crops • More total days of growth • Density-concentration, risk of crop loss/damage due to pests, pathogens • Greater reliance on nonrenewable resources/materials
------------------------------------------------------------------------------------------------------------------------------------------------------------------------------------------------------------------------------------------------------------------------------------	----------------------------------------------------------------------------------------------------------------------------------------------------------------------------------------------------------------------------------------------------------------------------------------------------------------------------------------------------------------------------------------------------------------------

25

Direct Sow

<p>Advantages</p> <ul style="list-style-type: none"> • Good for tap-rooted crops • Cost effective for large scale • Tend toward hardiness • Less time to grow • Less labor & Materials • Multiple Seeding Techniques 	<p>Disadvantages</p> <ul style="list-style-type: none"> • Subject to growing season & weather • Thinning, seed waste • Inconsistent germination • Risk of Crop Failure • Local Climate challenges • Limited in Crop Varieties
---------------------------------------------------------------------------------------------------------------------------------------------------------------------------------------------------------------------------------------------------------------------------------------------	------------------------------------------------------------------------------------------------------------------------------------------------------------------------------------------------------------------------------------------------------------------------------------------------------

26

Hardening Off

- Exposing transplants to outdoor conditions
- Process
 - Buy your transplants at least 1 week before planting
 - Place outside in shaded, protected spot to start for a few hours each day
 - 2nd and 3rd day: outdoors for 6 and 8 hours
 - 4th day: outside when it warms up; inside as sun dips
 - 5th day: outside when it warms up; inside after dinner
 - 6th day: outside when it warms up; inside when bed
 - 7th day: outside all night

27

Tomatoes

- Warm climate crops
- Need transplanting to be successful in this climate
- Full sun
- Soil: pH 6.0-6.8; well-drained, fertile is best; loams = high yields and well-drained = earlier harvest
- 50-90 degrees air temp for best growth.
- Seed viable for 5-7 years. 5-14 days to germinate.
- Over 2,000 varieties
- Determinate or indeterminate

28

Choose the best type/variety

Determinate Tomatoes

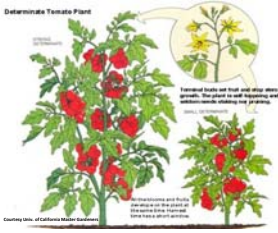

- Often called "bush" tomatoes
- Grow vertically at first, and then growth will take place on the side shoot
- Crop bearing period is short
- The plant requires minimal staking
- Tend to be more compact and manageable but not always
- Suitable for container planting
- Do not require heavy pruning or sucker removal for good crop yield

29

Choose the best type/variety

Indeterminate Tomatoes

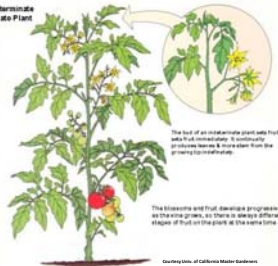

- Continue to flower and bear fruit over the course of the season until the plant is killed by frost
- Can grow tall
- Require staking or caging for support
- Require removal of suckers: wait until two leaves develop before removing

30

When to transplant out

- Frost free nights
- Daytime temperatures consistently above 60°
 - A week below 55° will stunt plants

OR

- Provide frost protection

Wall-of-Water® provides frost protection down to the mid-teens

- Cool soil temperatures also limit growth.
 - ✓ Use plastic mulch to warm the soil.

492

31

Plant Health Care
Growing Tomatoes

Purchasing the ideal transplants

- Bright grassy green color
- 6-8" tall
- Pencil diameter

In a warm greenhouse, tomatoes quickly become tall and leggy.

492

32

Planting the tall, leggy tomato transplant

Plant horizontal or deep

- Roots love warmer surface soils.
- Readily root out along buried stem.
- Place transplants in trench 2-3" deep.
- 2 sets of leaves above ground.
- Pinch off leaves below ground.

493

33

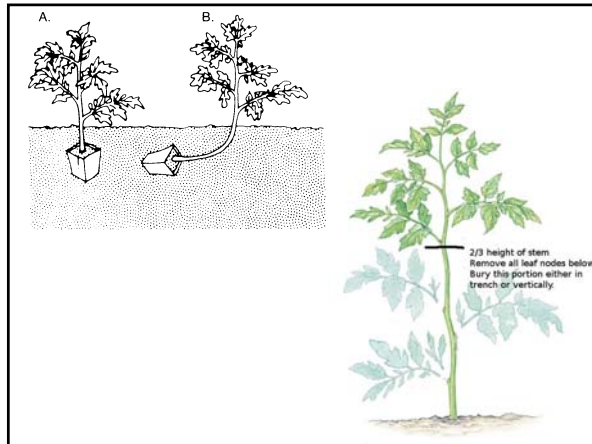

34

Plant Health Care
Growing Tomatoes

Trellis

Space trellised tomatoes 2 feet apart

Cages made with concrete reinforcing mesh

Remove bottom ring of wire to stick in ground.

- Slows spread of *Early Blight*
- Easy to harvest
- Eliminates ground rot on fruit

493

35

Using plastic mulch

- Must be planted early so plant growth covers plastic before summer heat comes on.
- Plastic fluttering in the wind pumps air into soil.
 - Covering plastic with mulch could reduce soil oxygen levels.
- Do NOT plow in plastic.
 - It will never decompose in the soil!

494

36

Plant Health Care
Growing Tomatoes

Pollination

- Night temperature below 55°
 - Pollen does not develop
- Daytime temperatures above 90° by 10 a.m.
 - Blossoms abort

494

37

Garden sanitation

Rotation

- 4 years minimum without
 - tomatoes
 - peppers
 - potatoes
 - eggplants
 - vine crops (squash and melons)
 - strawberries
 - raspberries
- **Not practical in home garden**

Blossom End Rot

Water imbalance

- Too wet
- Too dry
- Root damage

495

38

Tomato Plant Care

- For smaller fruited tomatoes, the more you pick the more it flowers/fruits. So watch your plant closely and pick often.
- Watch you tomatoes – most are ready 40-60 days after blossoms open

39

Tomato plant care – July/August

- Start topping your indeterminate varieties – 6” off terminal growth
- Remove newly setting blossoms and small green fruit (from larger varieties)
- Keep suckering!



40

Tomato plant care – soon(ish)

- Sacrifice some of the fruit to benefit the ones you hope to ripen on the plant
- Trap the heat!
- Ethylene (ripening hormone) slows down as temps go below 50F (why we sometimes have the ever-green September tomato)

41

Maturity & Ripening Stages

MG: ethylene and temperature to ripen
VR: manage ripening with temperature

- 1 GREEN** The tomato surface is completely green. The shade of green may vary from light to dark.
- 2 BREAKERS** There is a definite break of color from green to bruised fruit Tannish-yellow, pink or red or 10% or less of the tomato surface.
- 3 TURNING** Tannish-yellow, pink or red color shows on over 10% but not more than 30% of the tomato surface.
- 4 PINK** Pink or red color shows on over 30% but not more than 90% of the tomato surface.
- 5 LIGHT RED** Pinkish-red or red color shows on over 60% but red color covers not more than 90% of the tomato surface
- 6 RED** Red means that more than 90% of the tomato surface, in aggregate, is red

VR = vine-ripe <http://www.ams.usda.gov/AM0v1.0/Grading>

42

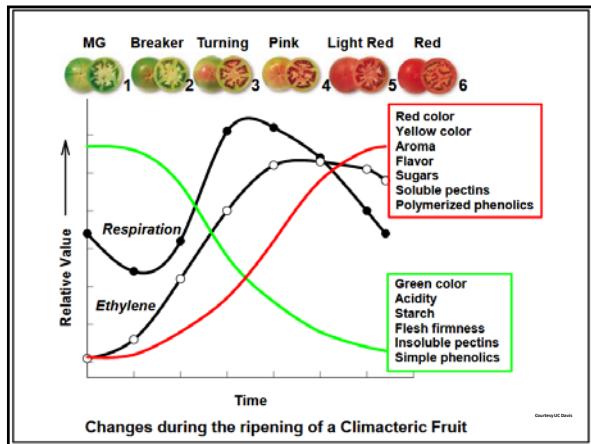

43

Tomato plant care – before the end

- Once the fruit reaches the “breaker” stage, it has the ability to ripen on, or off, the plant
- Either harvest those fruit and bring inside – or, take the whole plant!

44

Harvesting Tomatoes

Harvesting Before Frost

- When you want to ripen fruit indoors, fruit by the stages:
 - “breaker” (10% red or pink)
 - “turning” (30% red or pink)
- Layer those that are at the breaker or turning stage in single layers in a box, separated by newspaper
- Place ripe tomato in each layer to stimulate ethylene production and ripening
- Place box in dark and dry spot

45

Harvesting Tomatoes

Handling

- Keep tomatoes in single or double layers to prevent squishing
- Wash with cloth

Storage

- Never store under 54 degrees, so not in the refrigerator
- 54-61 degrees for slow ripening, 61-86 for rapid ripening

46

Choices, choices, choices

- Sun gold (I)
- Sweet 100's (I)
- Big Beef I)
- Golden Girl (D)
- Park's Whopper (I)
- Celebrity (D)
- Better Bush (D)
- Early Goliath (I)
- Fourth of July (D)
- Anything with 'Siberian' or 'Arctic' in name
- Look for Days to Maturity < 75

47

Peppers

- Similar to tomatoes – warm season crop. Optimal temperatures: sweet = 65-90 degrees; hot: 75-90.
- Full sun and can also grow under protection of greenhouse for proper heat requirements.
- Need transplanting to be successful in this climate. Seedlings are very slow to develop - start seeds 10–12 weeks prior to your target transplanting date.
- Like tomatoes, plant deeply to encourage adventitious rooting.

Soil:
Sandy loam, good drainage. pH 6-6.8. Consistent watering.

48

Choose the best transplants

- Choose transplants with a strong root system with 10+ leaves
- Transplants already displaying flowers and fruit at the garden center are less desirable, as this can be caused by stress
- If transplants do have early fruit or flowers, remove them for first 3-4 weeks
- Notorious for being slow to grow

49

Choose the best type/variety

- Fruits going to color tend to add about 3 weeks
- Think small!
 - Padron
 - Shishito
 - Jalapeno
 - Corno di Toro
 - Cherry peppers

50

Peppers

- Need high levels of N to establish plant size and leaf canopy (sunburn).
- High amount of fruit = high amount of water (stress imparts poor flavor)
- Staking is good idea.
- Peppers stems are relatively weak so harvest with clippers and leave 1/4" to 1/2" of stem
- Harvest the crown fruit first (may be sacrificial)

51

Pepper facts/notes

- No such thing as a sweet pepper in the wild (breeding)
- Colored peppers = increase in nutrition and sugar
- Colored peppers = risk of predation and disease and frost damage
- There are no green mature peppers

52

Peppers – Capsaicin

- NO flavor, odor, or color (but found in yellow-colored sacs called vesicles)
- Capsaicinoid vesicles typically found in placenta but with super-hot varieties can also be found in flesh
- Heat measured on the Scoville Heat Unit
 1. Carolina Reaper: 2,200,000 SHU
 7. Ghost Pepper (Bhut Jolokia): 1,040,500 SHU
 Further down: Habanero (Scotch Bonnet): 325,000 SHU
 Jalapeno: ~ 8,000 SHU
 Green Chile: 2,500 – 5,000 SHU

53

Asparagus

- Hardy, early-season perennial grown for spears.
- Full sun to part shade
- Newer varieties are predominately male.
- Mulch plants throughout year – summer mulch regulates moisture and suppresses weeds; fall and winter mulching provides cold protection for the roots.

Soil:
Tolerates wide range – must be well-drained. Likes higher pH and lots of compost or manure (when planting and top-dressed in subsequent years)

54

Asparagus

Planting

- Soak crowns (in shade) for a couple of hours in warm water. Do not expose roots to sun or wind.
- Work 4" of compost or well-aged manure into furrow that is 6" wide by 5-8" deep. Plant crowns in furrow 14-18" apart.
- As spears grow, gradually fill with soil.

Other

- Do not cut back ferns until they are brown. Leave until spring to catch snow.
- Heavy feeder

496

55

Asparagus

Harvest

- Do not over harvest!
- Do not harvest until second season after planting
- Harvest period is approx. late April to early June
- Snap or cut at soil line.
- Choose finger size or larger – once they are continually pencil size or smaller, stop harvesting.

496
496

56

Varieties

- Jersey Giant
- Jersey Knight
- Jersey Supreme
- Purple Passion

57

Crop Culture

Beans

- Tender, warm season annuals grown for green pods & seeds. Beans planted late spring, early summer.
- Need 65-85F for germination. 6-17 days to germinate, seed viable for 3 years.
- Direct sow 2 inches deep, spacing varies.
- Prefer well-drained, sandy loam soil. Any drained soil will do.
- Fixes N through rhizobia.
- Low salt tolerance.
- Likes water (1"+ per week).
- Pod set is poor when temps exceed 90F.
- Beans either bush or pole

58

Crop Culture

Peas

- Peas are planted in early spring. Beans planted late spring, early summer.
- Need 40-75F for germination but long time to germ at cooler temps
- Can tolerate moderate freezes
- Plant 1-2" deep and 4" apart – shallow plant when soils are cool and wet
- Trellis!
- Can plant fall crop in late summer – peas don't like the heat of summer
- Low salt tolerance.
- Susceptible to powdery mildew

59

Harvesting Beans & Peas

Harvesting

- **Green or "wet" beans are picked just before seeds swell, every 2-3 days - mature pods slow production of new pods**
- **Be careful pulling stems off the plant - use both hands**
- **"Dry" beans mature until beans harden & pods are papery**
- **Peas are sweetest just before skin toughens, darkens**

60

Harvesting Beans & Peas

Handling

- Dry beans are sun-dried, shelled, winnowed
- Sort & cull soft or moist beans (for dry beans)
- Wet beans & peas can be briefly rinsed, but usually unnecessary

Storage

- Wet beans & peas save in a plastic bag in the fridge for 1-2 weeks
- Dry beans are kept in a cool, dark, dry place & can store for a year or more

61

Varieties

- Blue Lake
- Provider
- Cosmos
- Fortex (I)

62

Crop Culture

Brassicas
(Cabbage, Kale & Collards, Kohlrabi, Turnips, Broccoli, Cauliflower)

Climate:
Cool season crops. Fall, Spring & Winter cultivation prevents bolting. Grow best in 65 degree air temp.

Germination:
Seeds germinate in 4-20 days, planted 1/2 inch deep. Can easily be direct sown, but commonly started indoors due to pest pressure, especially flea beetles that eat young leaves. When transplanting, plant to base of first true leaves to encourage adventitious rooting.

Soil:
Slightly heavy loam that retains moisture. pH 6-7.5 for most varieties except cauliflower thrives in 6.5-7 pH. Needs 45-85 degree soil except cauliflower needs at least 55 degrees. Benefit from high N left behind by legumes.

63

Cole Crops
Broccoli, Brussels Sprouts, Cabbage, Cauliflower

<p><u>Temperatures</u></p> <ul style="list-style-type: none"> • Prefer 65° to 80° • Freeze low 20°s (established plants) • Fall crop <ul style="list-style-type: none"> • Direct seed mid-July • Spring crop <ul style="list-style-type: none"> • Young transplants • 4 weeks old, 4" tall 	<p><u>Cabbage Aphids</u></p> <ul style="list-style-type: none"> • Waxy body protect from predators • Wash off • Common insecticides
--------------------------------------------------------------------------------------------------------------------------------------------------------------------------------------------------------------------------------------------------------------------------------------------------------------------------------------------------------------------------------------------------------------	-----------------------------------------------------------------------------------------------------------------------------------------------------------------------------

498
498

64

Harvesting Broccoli & other Brassicas

Harvesting

- Several harvests of broccoli are possible per plant, if kept from flowering
- Broccoli is ready just as the head loosens, before bolting- cut stem at the base of the head or baby broccoli w/ long stems
- Cabbage is ready when head is firm, smooth, hard- cut at the base of head, strip off old leaves
- Brussel sprouts can be harvested by the sprout or cut at the axillary buds & kept on the stem

65

Harvesting Broccoli & other Brassicas

Handling & Storage

- Soak heads in water to draw out pests- earwigs
- Broccoli has short shelf life, 1-2 weeks in fridge
- Cabbage, brussel sprouts, kohlrabi keep for 3-8 weeks with proper storage in a plastic bag, in refrigerator

66

Varieties

Broccoli

- DiCiccio (SS)
- Green Comet (H)
- Green Goliath (SS/H)

Kale

- Winterbor
- Toscano
- Redbor

Cabbage

- Farao
- Tiara
- Golden Ace
- Primax
- Pac and Boc Choy

67

Sweet Corn

- Warm season crop
- Germination temps: 65-85F - Will not germinate < 55 F
- Requires rich, fertile soil
- 1" deep and 4-6" apart – can thin to 8-12" when ankle-high
- Heavy feeder – may need to side-dress multiple times
- Good to rotate with legume to meet nitrogen need
- Plant in blocks at least 4 rows wide of same hybrid: pollination
- Lots of roots near soil so weed carefully
- Water stress delays silking, but not tasseling

68

Sweet Corn

Variety types

- Normal sugar
- Sugar Enhanced (se)
 - Slower sugar loss
 - Isolation helpful
- Super Sweet (sh)
 - Increased sugar
 - Isolation required
 - 300-500 feet
 - 14 days

69

Sweet Corn

Yield = water + N + space

- Heavy feeder
- Water stress delays silking, but not tasseling

Wind Pollinated

- Plant in block
 - 4-5 rows wide

70

Lettuce, Spinach & Garden Greens

- Cool season annual crops. Thrives in fall & spring, as well winter under cold frames.
- Needs temps between 35-75F. Above 75F causes thermodormancy.
- Can be transplanted or direct sown. Lettuce germ is 3-7 days, Spinach 6-12 days.
- ¼- to 1/8" planting depth. 4" apart for leaf; 6" for head lettuce
- Can be grown in part shade
- 30-80 days to harvest, with temps. below 80 degrees
- Heat and long day length encourages bolting & bitterness
- Likes season extension
- Shallow root system so keep soil moist (mulch too)
- As season progresses plant more bolt-resistant varieties

71

Leafy Vegetables
Lettuce, Spinach, Chard, etc.

Types

- Crisphead (iceberg) – usually form head ~ 70 days
- Butterhead (bibb) – also forms head, but softer and more pliable ~ 65-70 days
- Leaf (red or green) – non-heading types, many choices ~ 50 days
- Cos (romaine) – elongated; thick ribs; "meaty" ~65 days
- Mesclun – young leaves, so succession planting is key; multiple cuttings ~25-40 days

72

Leafy Vegetables
Lettuce, Spinach, Chard, etc.

Rapid growth

- Rich soil
- Mulch
- Keep soil moist
- Spacing
 - 1/4" deep
 - 4" apart for leaf; 6" for head lettuce
 - rows 12" to 18" apart

73

Harvesting Greens

Harvest

- Early morning when it's cool - not frozen, not wilted
- By the leaf or by the head
- Several cuttings from one plant (spring mix, cilantro)
- Clean & weed as you go
- Knife or scissors, sharper the better

Handling

- Remove field heat to preserve turgidity
- Pick out weeds, old leaves, pests
- Spin off moisture to prevent rot

Storage

- In plastic bag or air tight container in fridge
- Good for 2-3 weeks

74

Onions

- Biennial, herbaceous plants, commonly grown as annuals.
- Planted in spring w/ late summer harvest
- Plant long-day or day-neutral varieties
- Full sun
- Wants rich, organic soil that retains moisture well.
- Sets: small bulbs less than 1" in diameter. Planted in the early spring.
- Seed: difficult here
- Transplants: give you bigger onions
- Plants in garden 4" apart

75

Crop Culture

Alliums
(onions & garlic)

Climate:
Biennial, herbaceous plants. commonly grown as annuals. 90-300 days, Planted in fall or spring w/ late summer harvest. Winter storage capacity.

Planting: Plant long-day or day-neutral varieties

- Sets: small bulbs less than 1" in diameter. Planted in the early spring.
- Seed: difficult here – usually need to plant before May 1 (1" deep)
- Transplants: give you bigger onions

Soil:
Rich, organic soil that retains moisture well. pH 6-6.8. Onions shed roots, which aids in improving soil texture.

76

Onion family

Photoperiod sensitivity

- Plant early
 - Long-day varieties (our latitude is 37° -40°)
 - 65° and
 - 14-16 hour daylight

Remove seed heads

Take note: planting after May 1st decreases the average bulb size, while planting before April 1st increases the chance of bolting

500

77

Alliums for Storage

Harvest

- Most of onion tops have fallen over
- Garlic tops turn brown

Can sometimes just pull out, but if not, loosen soil around crop

Storage

- Dry or cure the onions in a warm, dry, well-ventilated location
- Spread out the alliums in a single layer
- Cure onions for 2 to 3 weeks until tops and necks are thoroughly dry and the outer bulb scales begin to rustle
- Store in mesh bags in a cool, dry, dark place (+/- 40 degrees)
- For 1-10 months

78

Varieties

- Candy
- Red Candy
- Superstar
- Cipollini

79

Garlic

- Soil prep: poor root system so soils need high fertility (and supplemental feeding) and need to be well-drained.
- Plant in fall:
 - Separate right before planting
 - Only plant biggest bulbs
 - Plant basal plate down and 2 to 3x the height of the clove
 - Plant 4-6" apart (stiff); 6-8" (hard); 8-10" (elephant)
 - Mulch and water
- Stiffnecks: pull off scape in late spring (can be used)

80

Garlic

Harvest

- When start of leaves turning yellow cut off irrigation (2-3 weeks prior to harvest, typically)
- Can sometimes just pull out, but if not, loosen soil around crop

Storage

- Similar to onions

81

Garlic Types

Stiffneck (hardneck):

- Produce stiff flower stalks (scapes)
- Form fewer, larger cloves per bulb
- 3 main types: purple stripe, rocambole and porcelain
- Easy to peel
- More complex flavors
- Much shorter storage life
- Probably the best choice for northern gardeners

82

Garlic Types

Softneck:

- Do not produce stiff flower stalks (scapes)
- Larger plants with soft neck so can be braided
- High clove count (high teens to forties)
- What you typically see in stores
- Difficult to peel
- Much longer storage life (6-10 months)

83

Varieties

- Music
- Rocambole
- German Porcelain
- Spanish Roja
- Inchelium (S)
- Silver White (S)

84

Potatoes

- Spring planted, fall harvested
- Full sun
- Asexually propagated. Use disease free potatoes, 2-3 oz seed piece with at least 3-4 eyes
- Plant into 8-18" trench.
- 8" deep in early May; 6" in mid-May; 4" in late-May
- 50-74F soil temp. pH 5-7, but they like sandy, acidic soils.
- Hill potatoes 2-3 times
- Spacing determines potato size (typically 8-12" apart)
- Heavy feeder, needs lots of water
- Disease prone

85

Potatoes

The new crop of potatoes grows above the seed piece.

To shield growing tubers from sunlight (which turns them green) soil is "hilled" (mounded) around the base of the plant. Straw mulch may be used as an alternative to hilling.

Labels: Seed piece, New potatoes, Soil line

501

86

Potatoes

Harvest and Storage

- 2-3 weeks after plants have finished flowering = "new potatoes"
- 2-3 weeks after the foliage dies back = large
- If by beginning of October plants haven't died back then cut foliage – can leave in ground for at least 1 week
- Brush or wash off dirt and let them dry
- Store your undamaged potatoes in a well-ventilated, dark, cool (about 40 degrees) location

501

87

Crop Culture

Carrots

- Cool season, biennial crop.
- Full sun but can tolerate light shade
- ¼ - ½" deep and 3-4" spacing

Germination:

- Soil moisture is critical! Several waterings daily to germinate.
- Do not allow the soil to crust.
- Ideal soil temps are about 70F but will germinate at lower
- Soil: Well-drained soil critical. Deep, loose, and fertile soils are the best for straightest and smoothest roots. No rocks!

88

Crop Culture

Carrots

Harvest:

- Decrease water as roots get close to maturity to reduce chance of cracking.
- Harvest when roots reach desired size.
- Can be left in ground in winter and dug as needed.

<p><u>Sizes:</u></p> <ul style="list-style-type: none"> • Finger: 3 to 4 inches • Short: 2 to 4 inches • Half-long: 5 to 6 inches • Cylindrical: 6 to 7 inches • Standard: 7 to 9 inches 	<p><u>Storage:</u></p> <ul style="list-style-type: none"> • Wash roots and trim tops to ½ inch. • Place in perforated plastic bags in fridge. • Can be kept in-ground under layer of mulch.
---------------------------------------------------------------------------------------------------------------------------------------------------------------------------------------------------------------------------------------------	------------------------------------------------------------------------------------------------------------------------------------------------------------------------------------------------------------------------------

89

Varieties

- YaYa
- Bolero
- Mokum
- Nelson
- Tendersweet
- Denver's Half Long

90

Beets

- Cool season crop. Grown in 45-75 temp range.
- Full sun to part shade
- Big seed, ¾ to 1" deep (seed is actually a fruit with 1-4 seeds enclosed, so thinning may be necessary)
- Can tolerate low fertility
- Fine tilth on seed beds & even watering in loose, well-drained soils
- Best color and flavor develops with cooler temps and bright sun

91

Crop Culture

Beets

Harvest:

- Greens can be harvested when of sufficient size.
- Roots larger than 3" in diameter tend to be woody.
- Harvest when roots reach desired size.
- Harvest spring planted beets before hot weather.

Storage:

- Wash roots and trim tops to 2"
- Place in perforated plastic bags
- Storage life 2-4 months

92

Varieties

- Touchstone (golden)
- Chioggia
- Merlin
- Bull's Blood
- Early Wonder
- Red Ace

93

Cucurbits
(cucumbers, squash, melons)

- Prefer warm weather, plant after last frost. Winter squash does not mean it's cold hardy
- Full sun
- Hand pollinate if no pollinators present.
- Germination at soil temps 65-100F, 80F optimum. Germ 3-10 days by direct sow or carefully transplant.
- Lots of plant, lots of space. Rich, loose soil. Roots can reach 6' under earth.
- Lots of water, yields rapid growth. Warm soil

94

Vine Crop
Cucumbers, Melons, Pumpkins, Squash

<p><u>Yields</u></p> <ul style="list-style-type: none"> • Direct seed • Young transplants <ul style="list-style-type: none"> • 4 weeks old • Challenging! • Continual harvesting 	<p><u>Pollination</u></p> <ul style="list-style-type: none"> • Male and female flowers • Hand pollinate if no pollinators are present
---------------------------------------------------------------------------------------------------------------------------------------------------------------------------------------------------------------------------------------------------------------	----------------------------------------------------------------------------------------------------------------------------------------------------------------------

503

95





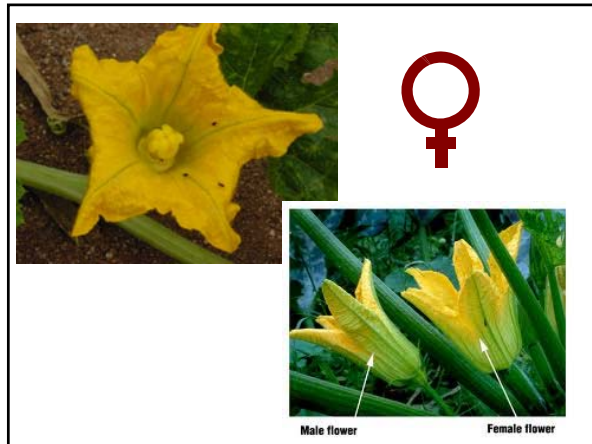

96

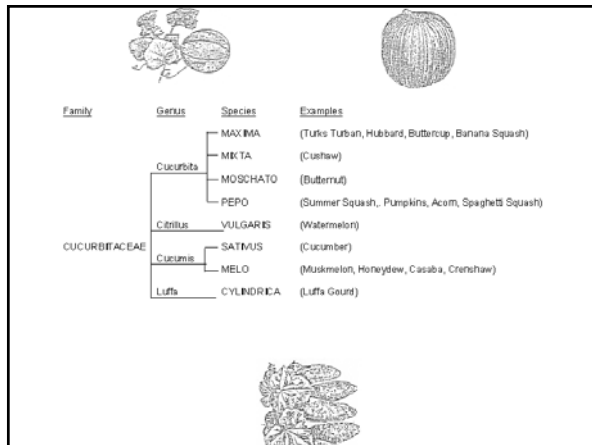

97



98

Harvesting Cucurbits

Handling

- Be careful not to scratch tender skin
- Use a cloth to brush off dirt
- Remove field heat, let air dry

Storage

- Short shelf life, usually 1-3 weeks
- Fridge is ideal, bagged in plastic

For Winter Squash

- Squash is ready when skin is hard, stem is woody
- Cut the stem as long as possible, careful not to break it
- Should be picked before first killing frost (below high 20s)

99

Harvesting Cucurbits (cont'd)

Handling

- Sort & cull soft skinned or frost damaged squash
- Can be cured before storing, at 80 degrees for 10 days
- Immaturely harvested squash don't always store well
- Mature color and be variable based on variety, peduncle is best point of reference

Storage

- Best conditions are 50-60 degrees, low humidity
- Store for 3-8 months, check them often, discard moldy ones

100

Site Selection

- Location - full sun
- Well drained
- Good soil - maintainable
- Fenced area
- Clear of shrubs & trees (root competition)
- Close to water source

101

Sunlight

- open, gradual slope is best
- south-facing or shade free place
- the majority of vegetables need a minimum of 6 hours of sunshine

102

Soil

Poorly drained soil will remain wet and cold late into the spring

- makes it difficult to grow early-season vegetables.
- If your soil is heavy and remains wet long after rain has stopped, consider using raised beds or add lots of organic matter.
- Raised beds will not only be better drained, they also will warm earlier.

103

Dealing with soil compaction

Annual applications of organic matter

Manage traffic flow with raised beds
 1st step ~ 75% maximum compaction
 4th step ~ 90% maximum compaction

Avoid tilling wet soils

Avoid excessive tilling

476

104

Nutrient Content of Manures and Vegetable Compost

Source	% Nitrogen	% Phosphorous	% Potassium
Chicken manure (fresh)	1.0	0.85	0.45
Chicken manure (dry)	2.0-4.50	4.6-6.0	1.2-2.4
Horse manure (fresh)	0.65	0.25	0.5
Cattle manure (fresh)	0.3-0.55	0.2	0.1-0.45
Steer or dairy manure (dry)	0.6-2.1	0.7-1.1	2.4-3.6
Swine manure (fresh)	0.5	0.3	0.5
Llama manure (fresh)	0.64	0.74	0.45
Sheep manure (fresh)	1.05	0.4	1.0
Rabbit manure (fresh)	2.4	1.4	0.6
Composted Yard Waste (ideal range)	1.0-2.0	0.6-0.9	0.2-0.5

105

Nitrogen release from OM is SLOW

In gardens with low organic content, compost or manure alone will NOT provide adequate nitrogen for high feeding crops like corn, potatoes, broccoli, cauliflower, and cabbage.



478

106

Starter fertilizers

Benefits

- Transplants hardened-off (growth slowed) to tolerate movement to windy outdoors
- Nitrate nitrogen gives signal to resume active growth
- Phosphate less available in cool soils
- **Recommended on vegetable and flower transplants**



479

107

Nitrogen "side dressing"

Depending on

- **Crop needs**
 - ✓ High N crops: corn, potatoes, cole crops (broccoli, cauliflower, cabbage)
- **Soil nutrient content**
 - ✓ Texture
 - ✓ Organic matter
- **Every 2-4 weeks**, to keep leaves "dark grassy green"



479

108

Fencing

Exclusion

- Above-ground fence (deer, rabbits, skunks, pets)
- Below-ground fence (p. gophers, p. dogs, voles)
 - ¼" to ½" mesh wire hardware cloth
 - bury at least 18" w/ bottom bent at 90° angle

109

Competition

Try to locate your garden away from trees and large shrubs.

- Roots from nearby woody plants will take nutrients and water away from your vegetables.

110

H₂O

Try to place garden where it is easy to care for (Who has had to drag the 50 foot hose each time?)

Think about efficient water techniques

- Drip
- Soaker hose
- Own valve

111

Water, water... maybe not everywhere

- Watering in a dry land means making some choices
- Certain plants require A LOT of water
- Sacrifices? *Beans have the highest water use of any common garden vegetable, using 0.25" of water per day when blooming and setting fruit.*

Critical watering periods for vegetables:
 You can target the timing and amount of water to add. As a rule of thumb, water is most critical during the first few weeks of development, immediately after transplanting, and during flowering and fruit production.

112

EAST BED

LETTUCE – COS 4/9	LETTUCE – GREEN BUTTER 4/9	SPINACH – SHARI 4/9	CILANTRO 4/9	CARROT – NAPOLI 4/16	LETTUCE – MESCULIN MIX 4/16	LETTUCE – GREEN BUTTER 4/16	LETTUCE – COS 4/16
LETTUCE – COS 4/9	LETTUCE – GREEN BUTTER 4/9	SPINACH – SMOOTH 4/9	RADISH 4/9	CARROT – NAPOLI 4/16	LETTUCE – MESCULIN MIX 4/16	LETTUCE – GREEN BUTTER 4/16	LETTUCE – COS 4/16
LETTUCE – COS 4/9	CARROT – RAINBOW 4/9	CARROT – NAPOLI 4/16	CARROT – NAPOLI 4/9	CARROT – NAPOLI 4/16	LETTUCE – MESCULIN MIX 4/16	LETTUCE – GREEN BUTTER 4/16	LETTUCE – COS 4/16
LETTUCE – COS 4/9	CARROT – RAINBOW 4/9	CARROT – NAPOLI 4/9	CARROT – NAPOLI 4/9	CARROT – NAPOLI 4/16	LETTUCE – MESCULIN MIX 4/16	LETTUCE – GREEN BUTTER 4/16	LETTUCE – COS 4/16

Sugar snaps
4/9

113

Square Foot Gardening

Steps:

- Beds should be about 4' wide by multiples of 4 long
- On top of each frame build a grid that divides the box into 1' squares – leave this grid in all season
- Depending on the mature size of the plant, grow 1, 4, 9, or 16 equally spaced plants per square foot

114

Square Foot Gardening

Dibble boards come in handy

Construction:

<http://beekman1802.com/general/a-homemade-dibble.html>



115

Square Foot Gardening

Spacing recommendations on seed packet:

- 12" apart, plant 1 per square
- 6" apart, plant 4 per square
- 4" apart, plant 9 per square
- 3" apart (or less), plant 16 per square

116

Crop Rotation

Why Rotate?

- build up the organic matter and soil nutrients
- increase plant vigor & improve soil structure
- control soil-borne diseases and insects
- vegetables in the same family grouping are likely to be susceptible to the same diseases and organisms
- Different crops take different nutrients out of soil
- Crops affect soil differently

Could be considered the most important practice in a multiple-cropping program!

117

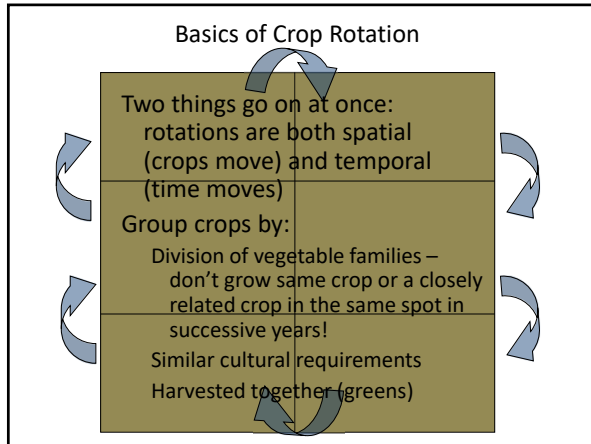

118

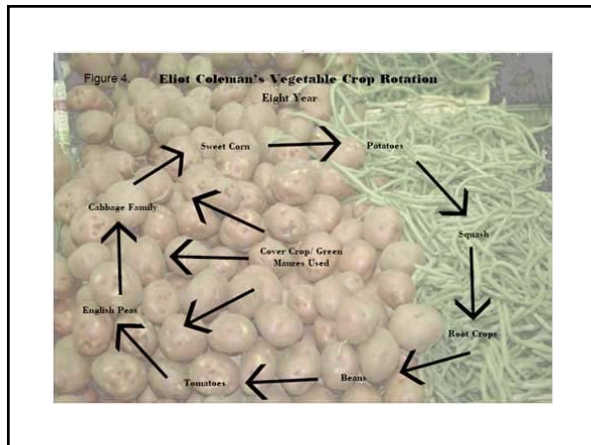

119

Solanaceae or nightshade family--tomato, pepper, eggplant, potato, tomatillo;

Onion family--onions, garlic, leek, shallot, chives;

Cucurbit or gourd family--cucumbers, muskmelon, watermelon, squash, pumpkin

Mustard or cole family--cabbage, broccoli, cauliflower, Brussels sprouts, kohlrabi, turnip, radish, Chinese cabbage, kale, collards, mustard greens, rutabaga;

Legume or pea family--garden pea, snap beans, lima beans, soybean;

Grass family (edible part is seed)--sweet corn, popcorn, ornamental corn;

Carrot family--carrots, parsnip, parsley, celery;

Goosefoot family--beet, Swiss chard, spinach;

Sunflower family--lettuce, Jerusalem artichoke, endive, salsify;

Mallow family (edible part is fruit)--okra.

120

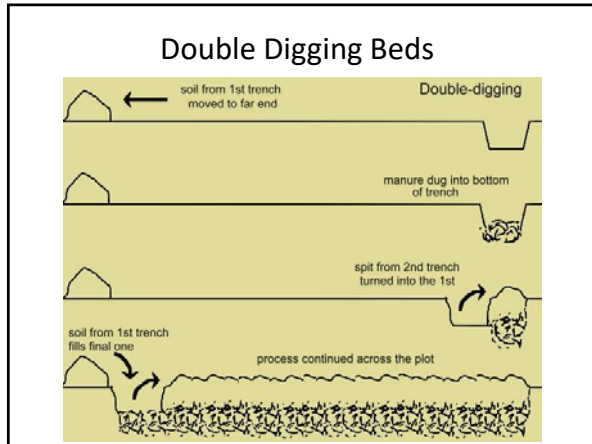

121

Insectary Gardens

If you miss the harvest of certain crops let them go to seed (umbels: fennel, parsely, carrot, dill)

- Comfrey
- Borage
- Yarrow
- Mustards
- Buckwheat
- Cosmos
- Clover
- Alfalfa
- Cornflower

122



Tachinid Flies

- Adults lay eggs on caterpillars, beetles, and bugs usually near head
- Eggs quickly hatch
- Maggots tunnel into host

123

Parasitoid Wasps

- Female ichneumonids have long ovipositor; inject eggs into larvae
- Braconids lay eggs on, or just under, surface





124

Predatory Insects



Predatory Mite



Ground Beetle



Spider



European Mantid

125

Raised Beds

- Easier to maintain
- Promote drainage
- No deep tilling needed
- If elevated high enough, can be ideal for people in wheelchairs
- Best choices: untreated wood, cinder blocks, recycled materials, bricks
- Higher yields
- Reduction in soil compaction
- Earlier planting
- Frost protection – easier
- Soil improvement

126

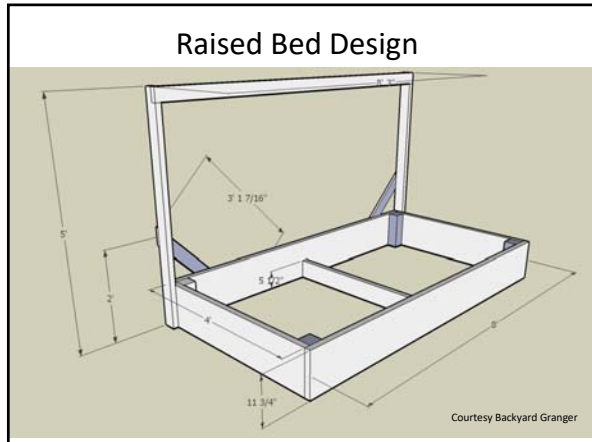

127

Types of Frost

Advection Frost

- Cold front moves into area
- Temperatures may be significantly below critical levels
- Protection often not worthwhile

Radiation Frosts

- Plants cool due to heat loss to space on calm, clear night
- Often only a few degrees below critical temperatures
- Protection often worthwhile

505

128

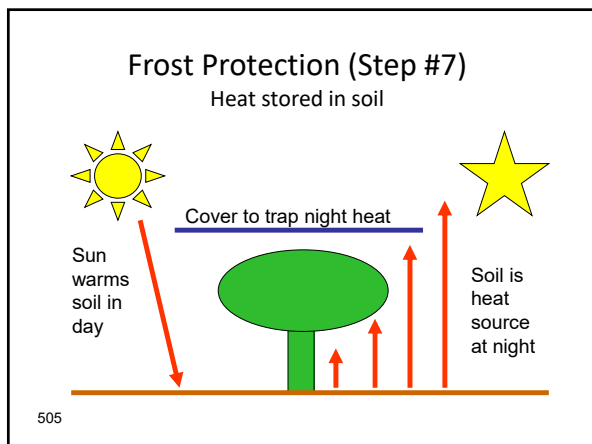

129

In Colorado mountain communities, microclimates play a major role in temperature and gardening potential

Learn from local observations what works at YOUR location!

130

What We Mean By “Season Extension”

- Add to the frost-free growing season length
 - So we can plant before the average last frost in Spring and avoid late frost damage
 - And help plants survive the first frost(s) in Fall to keep producing
- Or add to the time and or conditions a specific crop needs to produce good quality
- Or getting more out of a season or space

131

Covers

- Hot caps
 - Cloches
 - Walls of water
- Row cover cloths
 - Synonyms: ‘remay’, ‘agribond’, ‘fleece’
- Low tunnels
- Cold frames
- Hot beds
- High tunnels/ Hoop houses
- Greenhouses

132

**Season Extension Covers
Advantages**

- Heat soil
- Raise air temperature during day
- Keep air temperature higher at night
- Keep temperatures more moderate
- Cool /shade plants
- Can exclude insect pests and other critters
- Protect from hail or wind

133

**Season Extension Covers
Disadvantages**

- Can overheat
- Can increase humidity
 - Increase diseases and insects
- Can exclude pollinators
- Might adversely affect flavor
- Salt can build up in soil under cover
- Can be too short for plants and restrict their growth

134

Solexx

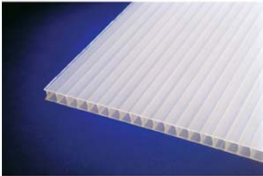

- Comes in 3 mm and 5 mm rolls
 - 5 mm for high altitude
- Claims “shatter-proof”
- Mildew resistant
- 75% light transmission

135

Diobetalon

- Made of PVA
- Attracts and holds water – cold nights, water can freeze to fibers and increase insulation
- High permeability
- 85-90% light transmission

136

Plastic Mulch

Use plastic mulch for earlier production

- Averages 2-3 weeks earlier production along Colorado's Front Range
 - 3-4+ weeks in cooler growing regions and in cooler summers
- Higher yields
- Controls weeds
- Reduces irrigation need
 - Be careful not to over water

137

Using plastic mulch

Put plastic mulch on early to warm soil

<ol style="list-style-type: none"> 1. Prepare soil and irrigation <ul style="list-style-type: none"> • Slightly mound soil so plastic makes direct contact with ground. 2. Cover growing bed with plastic <ul style="list-style-type: none"> • Bury <u>all</u> edges 2-4" deep. • Staple on <u>side</u> of raised bed box. 	<ol style="list-style-type: none"> 3. Plant by cutting holes <ul style="list-style-type: none"> • Do not "X" as hot plastic touching plants can burn. • Must be planted early so plant growth covers plastic before summer heat comes on • Covering plastic with mulch could reduce soil oxygen levels • Do NOT plow in plastic <ul style="list-style-type: none"> • It will never decompose in the soil!
-----------------------------------------------------------------------------------------------------------------------------------------------------------------------------------------------------------------------------------------------------------------------------------------------------------------------------------------------------------------------------------------------------------------	---------------------------------------------------------------------------------------------------------------------------------------------------------------------------------------------------------------------------------------------------------------------------------------------------------------------------------------------------------------------------------------------------------------------------------------------------------------------------------------------------------

138

Floating row covers

- Lightweight
- Lay directly on crops
- Transmit light
- 2 – 4 degrees protection
- Cut wind and insects
- What do we need to be worried about?

506

139

Floating row covers

- Insulates seeds and young plants for a healthy head start
- Less handling and mess than unsightly straw
- Lightweight, breathable 100% polyester creates a physical barrier to birds, animals
- Apply water and fertilizers on top of fabric; no removal required
- Ideal for multiple season use, spring and fall

506

140

Row cover weight

Light

- Excellent light and water transmission
- Pest exclusion
- Little frost protection
- Tear easily (single season use)

Medium

- Good light transmission (75-85%)
- Good frost protection
- Durable (several seasons)

Heavy

- Poor light transmission (50%)
- Excellent frost protection
- Very durable (4+ years)

506

141

Pollination

Many vegetables do not require pollination because the fruit (seedbearing body) is not harvested. Row can be left on until harvest.

- Leafy vegetables (e.g. lettuce, cabbage, kale)
- Root vegetables (e.g. carrots, potatoes)
- Stem vegetables (e.g. celery, rhubarb, chard)

Row covers are usually removed at flowering for insect and wind-pollinated crops, such as melons and squash. They can be replaced after fruit set.

142

Supported Row Cover

Plastic cover on concrete mesh frame

Plastic must be held up off plants or the plants will freeze where touched by plastic

2° to over 6° frost protect

- Great for cool season crops that tolerate some light frost
 - Add 2-6 weeks on each end of growing season
- Poor for warm season crops that are intolerant of a dip to 32°

506

143

Frost Covers

Plastic over mesh frame + space blanket

Following a sunny day in April, dipped to 20° at night and did NOT freeze



507

144

Frost Covers
Plastic over mesh frame + Christmas lights

Up to 18° frost protection

- One string (25 lights) C-7 Christmas tree lights per 20 square feet



508

145

Frost Covers
Plastic over mesh frame + Christmas light and space blanket

18° to over 30° frost protection

- One string (25 lights) C-7 Christmas tree lights per 20 square feet

508

146

Cold Frames / Hot Beds

- Mini greenhouses
- Old windows
- Plastic film on wood frame
- Rigid plastic
- Hinged top needed to regulate heat
- Used to harden off plants before going to field

147

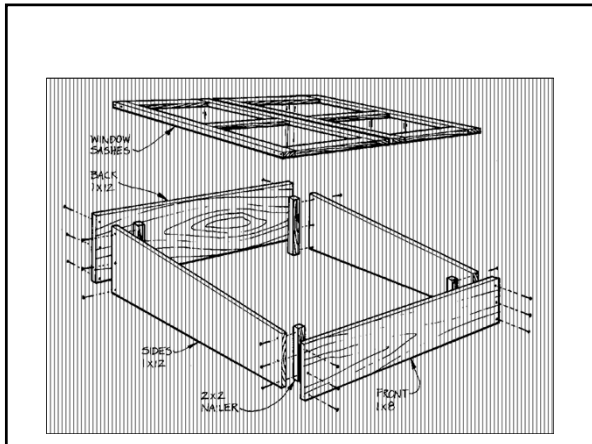

148

What is the difference between a high tunnel and a hoophouse?

- Terms sometimes interchangeable
- High tunnels-single layer of poly
- Hoophouse-double layer of poly
 - Inflated with fan
 - Better insulation
 - More expensive? (double poly)

149

Structural Materials

Frames

- PVC
- Aluminum
- Steel

Film plastic (polyethylene)

- UV resistant
- 6 mil thickness is most common
- 4 yr poly
- Double or single layer

150

Site and other considerations

- Drainage
 - Is the site level?
- Snow load
- Wind
 - Prevailing winds
 - Max gusts - can the structure handle it?
- Light and winter shading
- Distance to utilities & road
 - Electricity
 - Irrigation water

151

Heat

Most hoophouses are unheated

- Propane heaters
- Alternative fuel heaters
- Water barrels (passive heat)
- Inner row covers add another 4+ degrees
 - Spun-bonded fabric cover over mini-hoops
 - Don't let foliage touch row cover-frost damage

152

Passive Heat



Pros: Cheaper heat
 Cons: Added expense
 Block light
 Reduce useable space

153

Resources

- csuhort.blogspot.com/
- extension.oregonstate.edu/sites/default/files/documents/12281/soiltemp_s.pdf
- www.gardening.cornell.edu/homegardening/scene0391.html
- casfs.ucsc.edu/about/publications/for_the_gardener.html
- Me

154

Questions or Discussion?



Darrin Parmenter
darrin.parmenter@colostate.edu
(970) 382.6464

155
